

HRW SERIES

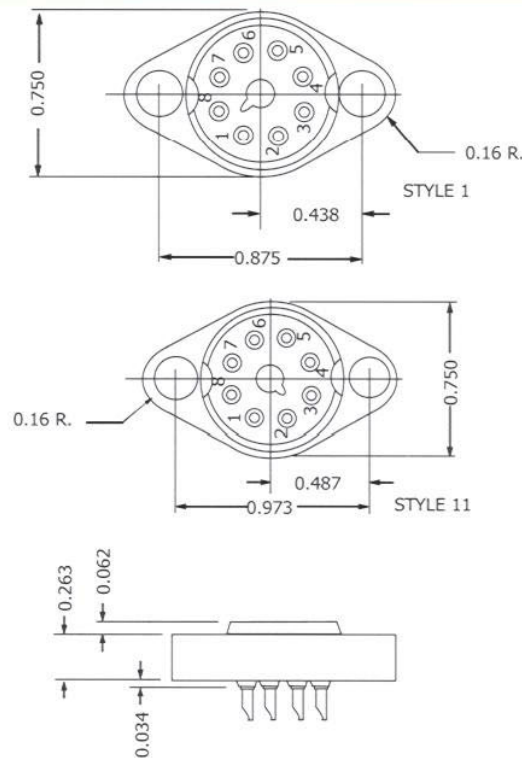
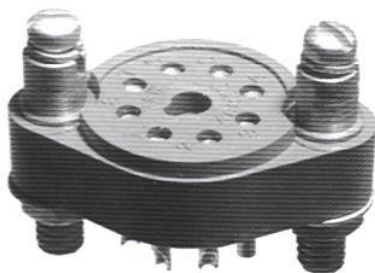

CONTACT DATA	CHASSIS MOUNTING DATA					
	CHASSIS THICKNESS	X-DIMENSION	STYLE	MOUNTING STYLE		
				BELOW CHASSIS	BELOW CHASSIS	ABOVE CHASSIS
 SOLDER CUP	1/16	.22	I	HRW-1		HRW-2
			II	HRW-5		HRW-6
	3/32	.19	I		HRW-31	
			II		HRW-35	
	1/8		I			
			II			
 EYELET	1/16	.22	I	HRW-9		HRW-10
			II	HRW-11		HRW-12
	3/32	.19	I		HRW-39	
			II		HRW-311	
	1/8		I			
			II			
 TURRET	1/16	.22	I	HRW-3		HRW-4
			II	HRW-7		HRW-8
	3/32	.19	I		HRW-33	
			II		HRW-37	
	1/8		I			
			II			
 TAPER PIN	1/16	.22	I	HRW-13		HRW-14
			II	HRW-15		HRW-16
	3/32	.19	I		HRW-313	
			II		HRW-315	
	1/8		I			
			II			

ELECTRICAL

Wire Size:

- Solder Cup Type One #20 AWG
- Turret Type Two #20 AWG or
Three #22 AWG
- Eyelet Type Two #20 AWG or
Three #22 AWG
- Taper Type One AMP "37" Taper
Receptacle

Current Rating

7.5 Amperes

Withstanding Voltage:

- Contact to Contact Sea Level 1800 VRMS Minimum
- Contact to Ground Sea Level 1500 VRMS Minimum
- Contact to Contact 70,000 Ft. 450 VRMS Minimum
- Contact to Ground 70,000 Ft. 375 VRMS Minimum

MECHANICAL

- Creepage Between Contacts 0.14 Minimum
- Air Space Between Contacts 0.06 Minimum
- Contacts to Accept 0.040 ± 0.001 DIA. Pins

Contacts:

- Spring Temper Grade "A" Phosphor Bronze, or
Heat Treated Beryllium Copper
- Gold Plated over Copper or Nickel Plate

Mounting Hardware:

- Special Studs, Screws, Lockwashers, and Nuts

Insulation Material:

- Choice of "MIL Approved" Thermosetting
Insulations (See Page 45)

Temperature Ratings: -65°C to +125°C

Weight of Socket with Mountings: 0.44 oz.

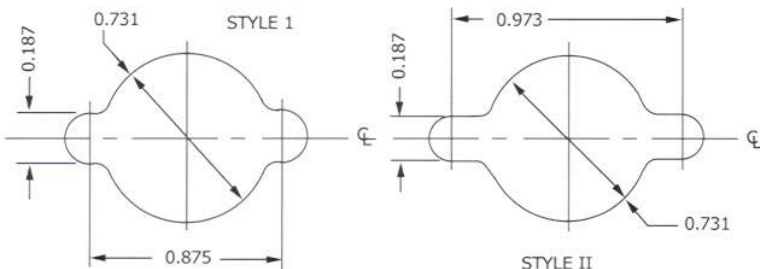

RECOMMENDED CHASSIS CUT-OUT