

4

3

2

1

REVISIONS				
ZONE	LTR	DESCRIPTION	DATE	APPROVED

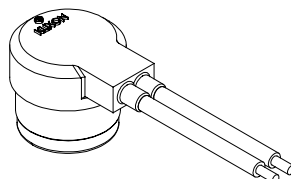
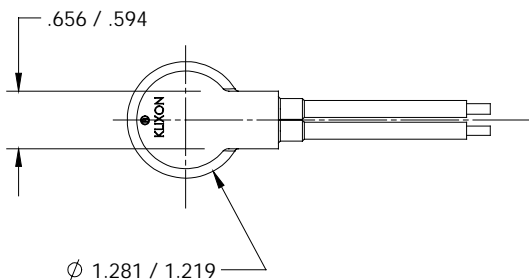

NOTES:

- 1) SWITCH LOGIC: SINGLE POLE SINGLE THROW
- 2) OVERMOLD MATERIAL- DOW CORNING #152 REDDISH BROWN SILASTIC RUBBER OR EQUAL.
- 3) WIRE AWG #18 SILICONE RUBBER INSULATED

D

D

C

C

B

B

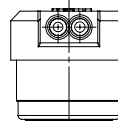
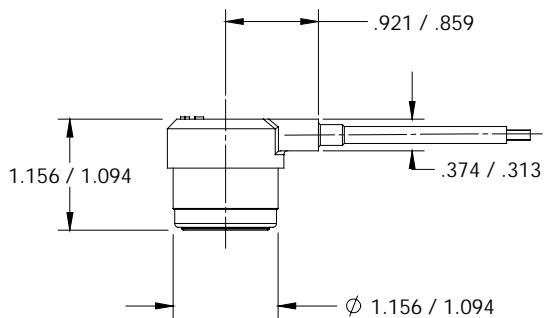

A

A

NEITHER THIS PRINT NOR THE INFORMATION CONTAINED THEREON IS TO BE USED AGAINST THE INTEREST OF TEXAS INSTRUMENTS, INC. OR AGAINST THE INTERESTS OF ANY OF ITS AFFILIATED COMPANIES OR WHOLLY OWNED SUBSIDIARIES.

FOR REFERENCE ONLY CONSULT TEXAS INSTRUMENTS CUSTOMER SERVICE FOR LATEST REVISION BEFORE USE

UNLESS OTHERWISE SPECIFIED DIMENSIONS ARE IN INCHES					THIS IS A CAD DRAWING THE GEOMETRY IN THE ASSOCIATED CAD COMPUTER FILE IS DIMENSIONALLY ACCURATE WHEN DRAWING IS BEING REVISED THE GEOMETRY MUST BE UPDATED IN ALL VIEWS AND ON ALL SHEETS				
DRAWN S. MARQUIS		DATE 3/25/02		TEXAS INSTRUMENTS ATILEBORO MA 02705			KLIXON CONTROL PRODUCTS DIVISION		
TOLERANCES ON FRACTIONS AND ANGLES		ENGINEER		TITLE THERMOSTAT SWITCH ENVELOPE DRAWING					
MATERIAL		APPROVED		SIZE B		CODE IDENT NO. 82647		4391S7 STYLE	
SIGNATURES ON FILE REFER TO ELECTRONIC CHANGE NOTICE				SCALE			SHEET		

4

3

2

1